



6-V to 38-V Input Power Management IC with WLED Driver

GENERAL DESCRIPTION

DF3117 is a highly integrated power management IC (PMIC) designed to minimize power consumption in consumer and multimedia applications. It is targeted at Smart Door Bell, Projector, Network Terminal Equipment, Industrial Power Systems.

Providing a complete system power management solution, the DF3117 integrates 4-CH synchronous buck converter, 1-CH WLED driver, 1-CH LDO. The converters are optimized for high efficiency (greater than 92%) and feature integrated low impedance FETs.

FEATURES

- High Efficient DC/DC Converter: 92~96%
Integrate 6-CH Output in QFN28L-4X4 Package
- WLED Driver(1-CH)
an Asynchronous step-up converter designed for driving up to 7 series white LEDs
- Buck DC/DC Converter (4-CH)
BUCK1: Input 3.4V~20V, output adjustable, load current to 2A
BUCK2: Input 3.4V~20V, output adjustable, load current to 2A
BUCK4: Input 6V~38V, output adjustable, load current to 2A
BUCK3: Input 2.5V~6V, output adjustable, load current to 2A
- High PSRR LDO (1-CH)
LDO: output adjustable, load current up to 500mA.
- Protection
Over Voltage Protection (OVP)
Under Voltage Protection (UVP)
Over current Protection (OCP)
Short circuit Protection (SCP)
Over thermal Protection (OTP)

APPLICATION

- Smart Door Bell
- Projector
- Industrial Power Systems
- Network Terminal Equipment



PRODUCT OPTIONS

BLOCK	INPUT VOLTAGE	OUTPUT VOLTAGE	CAPABILITY
BUCK1/BUCK2	3.4~20V	Adjustable	2A
BUCK4	6V~38V	Adjustable	2A
BUCK3	2.5~6V	Adjustable	2A
WLED Driver	3.4~20V	30V MAX	1A
LDO	2.5V~6V	Adjustable	500mA

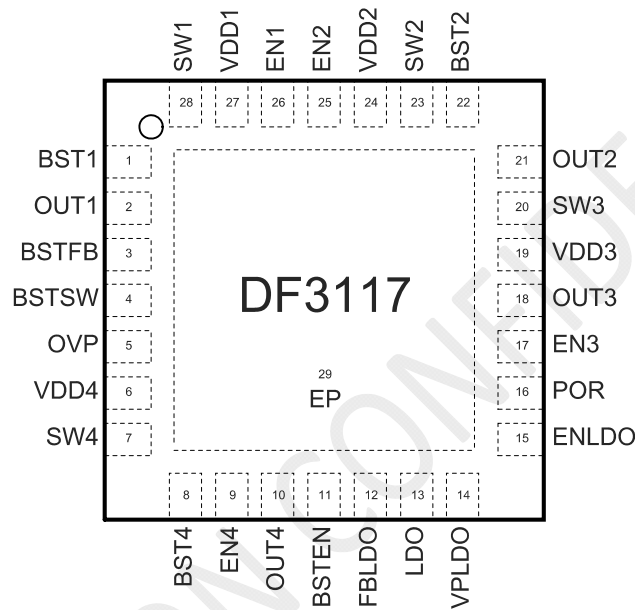
PIN CONFIGURATION

PIN DESCRIPTIONS

PIN	NAME	DESCRIPTION
1	BST1	Bootstrap. A capacitor connected between SW1 and BST1 pins is required to form a floating supply across the high-side switch driver. Use a 22nF capacitor
2	OUT1	BUCK1 Feedback. Connect to the tap of an external resistor divider from the output to GND to set the output voltage.
3	BSTFB	Adjustable version feedback input. Connect BSTFB to the center point of the external resistor divider.
4	BSTSW	BOOST Switching Pin, Connect this Pin to inductor and catch diode, Minimize the track area to reduce EMI.
5	OVP	Over Voltage Protection Pin, Voltage sensing input to trigger the function of over voltage protection.
6	VDD4	BUCK4 Power supply Pin, Bypass 10μF capacitor to GND to reduce the input noise.
7	SW4	BUCK4 Switching Pin, Connect this Pin to inductor, Minimize the track area to reduce EMI.
8	BST4	Bootstrap. A capacitor connected between SW4 and BST4 pins is required to form a floating supply across the high-side switch driver. Use a 10nF capacitor
9	EN4	BUCK4 Enable (Active High) or Disable(Low or Floating).
10	OUT4	BUCK4 Feedback. Connect to the tap of an external resistor divider from the output to GND to set the output voltage.
11	BSTEN	BOOST Enable (Active High) or Disable(Low or Floating).
12	FBLDO	LDO Feedback. Connect to the tap of an external resistor divider from the output to GND to set the output voltage.

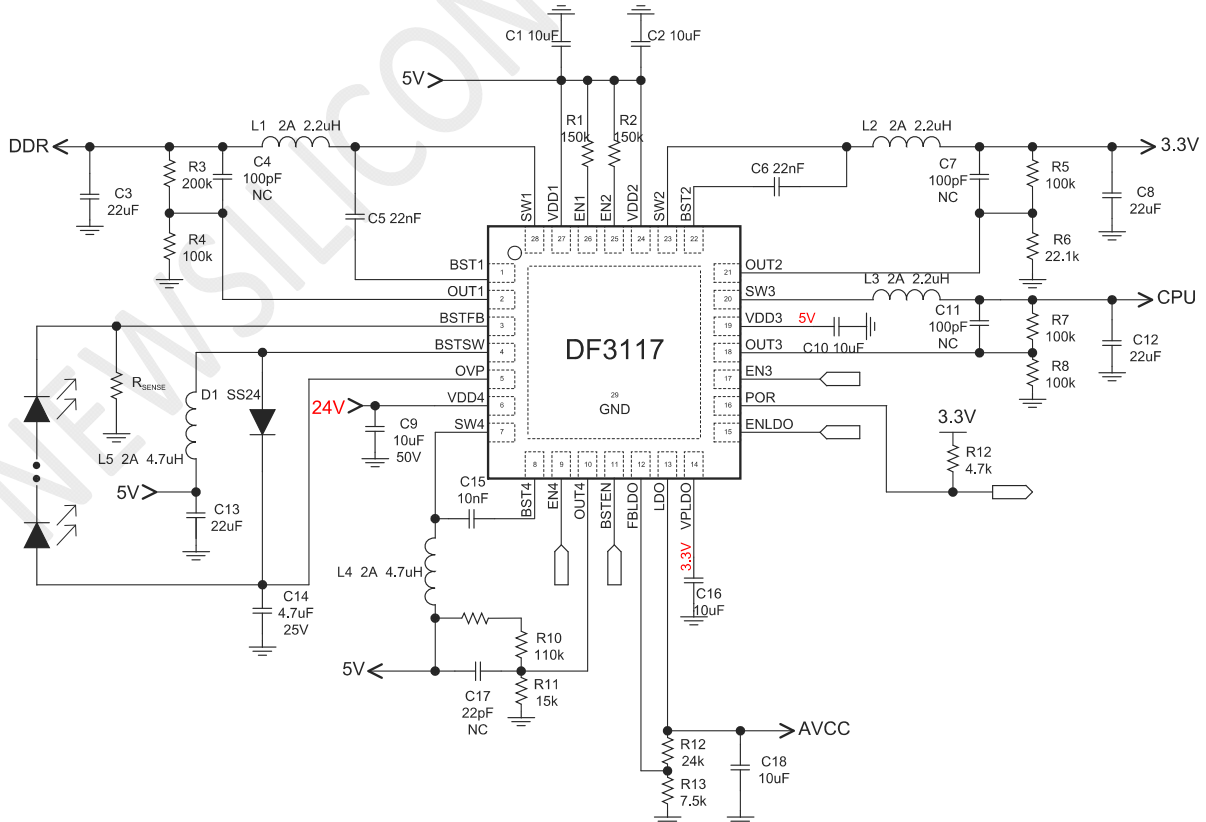

13	LDO	LDO Output pin, Bypass 10 μ F capacitor to GND
14	VPLDO	LDO Power supply Pin, Bypass 10 μ F capacitor to GND to reduce the input noise.
15	ENLDO	LDO Enable (Active High) or Disable(Low or Floating).
16	POR	Power On Reset
17	EN3	BUCK3 Enable (Active High) or Disable(Low or Floating).
18	OUT3	BUCK3 Feedback. Connect to the tap of an external resistor divider from the output to GND to set the output voltage.
19	VDD3	BUCK3 Power supply Pin, Bypass 10 μ F capacitor to GND to reduce the input noise.
20	SW3	BUCK3 Switching Pin, Connect this Pin to inductor, Minimize the track area to reduce EMI.
21	OUT2	BUCK2 Feedback. Connect to the tap of an external resistor divider from the output to GND to set the output voltage.
22	BST2	Bootstrap. A capacitor connected between SW2 and BST2 pins is required to form a floating supply across the high-side switch driver. Use a 22nF capacitor
23	SW2	BUCK2 Switching Pin, Connect this Pin to inductor, Minimize the track area to reduce EMI.
24	VDD2	BUCK2 Power supply Pin, Bypass 10 μ F capacitor to GND to reduce the input noise.
25	EN2	BUCK2 Enable (Active High) or Disable(Low or Floating).
26	EN1	BUCK1 Enable (Active High) or Disable(Low or Floating).
27	VDD1	BUCK1 Power supply Pin, Bypass 10 μ F capacitor to GND to reduce the input noise.
28	SW1	BUCK1 Switching Pin, Connect this Pin to inductor, Minimize the track area to reduce EMI.
29	EP	Thermal PAD, connect to Ground.

TYPICAL APPLICATIONS





SYSTEM BLOCK DIAGRAM

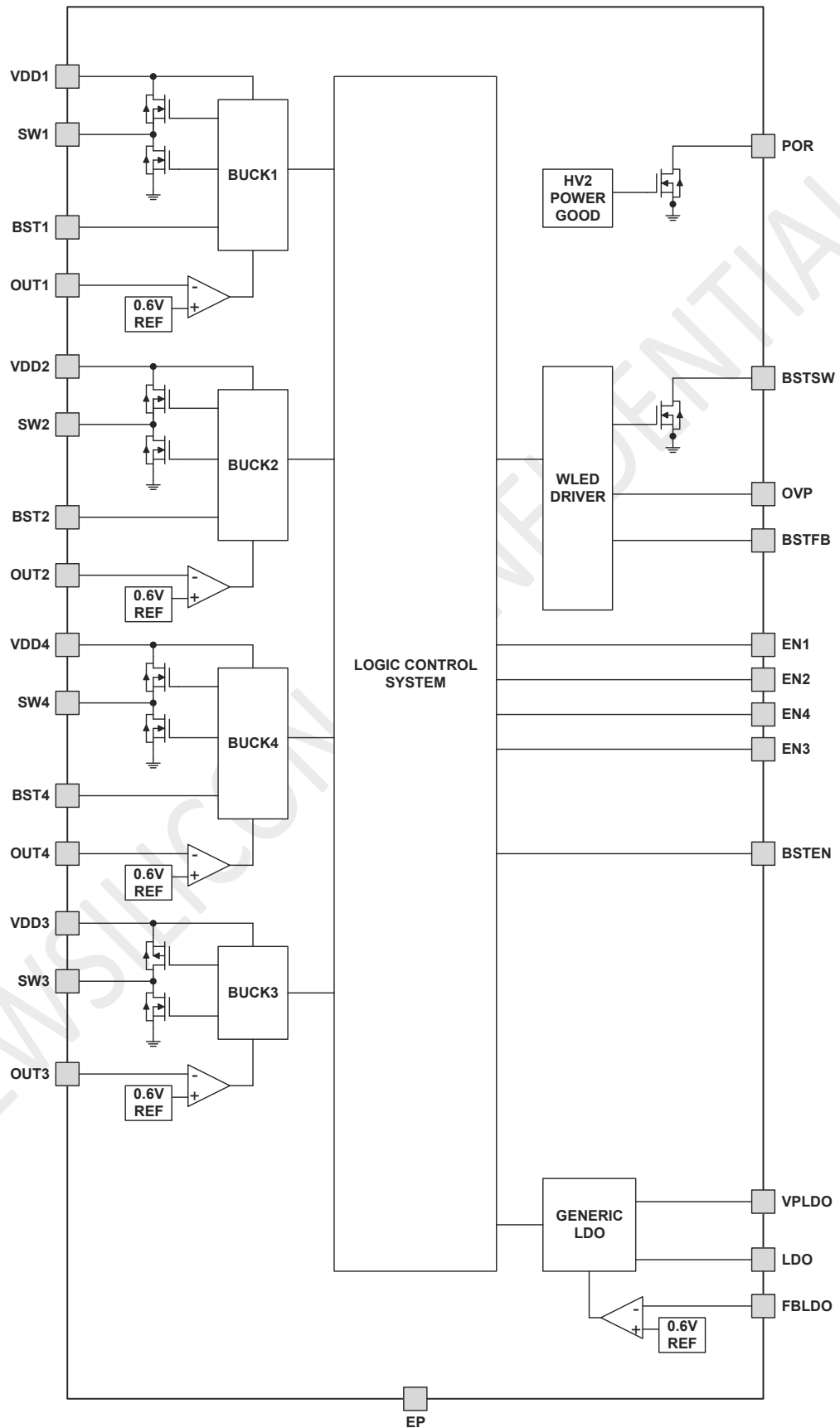

ABSOLUTE MAXIMUM RATINGS

PARAMETER	MIN	MAX	UNIT
VDD4,SW4,EN4	-0.3	42	V
VDD1,SW1,EN1	-0.3	30	V
VDD2,SW2,EN2	-0.3	30	V
BSTSW,OVP	-0.3	30	V
BST1,BST2,BST3		SWX+6	V
Other pin Voltage	-0.3	10	V
Junction Temperature		140	°C
Operating Temperature	-40	125	°C
Storage Temperature Range	-55	150	°C
Lead Temperature		300	°C
Power Dissipation, $P_D@T_A=25^{\circ}C$, QFN28L 4X4		2.5	W
HBM(Human Body Mode)		2	kV
MM(Machine Mode)		200	V

ESD(electrostatic discharge) sensitive device.

Charged devices and circuit boards can discharge without detection. Although this product features patented or proprietary protection circuitry, damage may occur on devices subjected to high energy ESD. Therefore, proper ESD precautions should be taken to avoid performance degradation or loss of functionality.

RECOMMENDED OPERATING CONDITIONS

PARAMETER	MIN	MAX	UNIT
VDD4,SW4,EN4	6	38	
VDD1,SW1,EN1	3.4	20	V
VDD2,SW2,EN2	3.4	20	V
BSTSW,OVP	3.4	30	V
Other pin Voltage	2.5	6	V

ELECTRICAL CHARACTERISTICS
BUCK1 & BUCK2 Electrical Characteristics

($V_{IN} = 12V$, $T_A = 25^{\circ}C$ unless otherwise specified)

PARAMETER	SYMBOL	TEST CONDITIONS	MIN	TYP	MAX	UNIT
Input Voltage Range	VDD1/2		3.4		20	V
Input UVP Threshold		Input Voltage Falling			3	V
Input OVP Threshold		Input Voltage Rising		20		V
Standby Supply Current		OUTX= 103% $I_{OUT} = 0$		400	600	μA
Shutdown Supply Current		ENX = 0, VDDX = 12V		3		μA
EN Rising Threshold	ENX	ENX RISING		1.4		V
EN Falling Threshold	ENX	ENX FALLING		0.6		V
Feedback Voltage	OUTX		0.588	0.6	0.612	V
Output Voltage Line Regulation				0.04	0.4	%/V
Output Voltage Load Regulation				0.5		%
Current Limit	I_{LIM}	Duty = 30%		3.5		A
Oscillator Frequency	F_{SW}			1.2		MHz
NMOS On Resistance	R_{ONN}	$I_{SW} = 100mA$		0.07		Ω

**BUCK4 Electrical Characteristics**(V_{IN} = 24V, T_A = 25°C unless otherwise specified)

PARAMETER	SYMBOL	TEST CONDITIONS	MIN	TYP	MAX	UNIT
Input Voltage Range	VDD4		6		38	V
Input UVP Threshold		Input Voltage Falling			5.3	V
Input OVP Threshold		Input Voltage Rising		38		V
Standby Supply Current		OUT4= 103% I _{OUT} = 0		110		μA
Shutdown Supply Current		EN4 = 0, VDD4 = 24V		3		μA
EN Rising Threshold	EN4	EN4 RISING		1.2		V
EN Falling Threshold	EN4	EN4 FALLING		1.0		V
Feedback Voltage	OUT4		0.588	0.6	0.612	V
Output Voltage Line Regulation				0.04	0.4	%/V
Output Voltage Load Regulation				0.5		%
Current Limit	I _{LIM}	Duty = 30%		3.5		A
Oscillator Frequency	F _{SW}			500		kHz
NMOS On Resistance	R _{ONN}	I _{SW} =100mA		0.07		Ω

BUCK3 Electrical Characteristics(V_{IN} = 3.6V, T_A = 25°C unless otherwise specified)

PARAMETER	SYMBOL	TEST CONDITIONS	MIN	TYP	MAX	UNIT
Input Voltage Range	VDD3		2.5		6	V
Input UVP Threshold		Input Voltage Falling		2.2		V
Input OVP Threshold		Input Voltage Rising		6.5		V
Operating Supply Current		OUT3= 60% I _{OUT} = 0		150	200	μA
Standby Supply Current		OUT3 = 103% I _{OUT} = 0		40	80	μA
Shutdown Supply Current		EN3 = 0 VDD3 = 4.2V		0.1	1	μA
EN Rising Threshold	EN3	EN3 Rising		1.4		V
EN Falling Threshold	EN3	EN3 Falling		0.6		V
Output Voltage Regulation Accuracy			-1.5	1	1.5	%
Feedback Voltage	OUT3		0.588	0.6	0.612	V
Output Voltage Line Regulation				0.04	0.4	%/V
Output Voltage Load Regulation				0.5		%
Current Limit	I _{LIM}	Duty = 30%		3.5		A
Oscillator Frequency	F _{SW}			1.2		MHz
PMOS On Resistance	R _{ONP}	I _{SW} =100mA		0.1		Ω
NMOS On Resistance	R _{ONN}	I _{SW} =100mA		0.07		Ω

LDO Electrical Characteristics(V_{IN} = 3.6V, T_A = 25°C unless otherwise specified)

PARAMETER	SYMBOL	TEST CONDITIONS	MIN	TYP	MAX	UNIT
Input Voltage Range	VPLDO		2.5		6	V
Input UVP Threshold		Input Voltage Falling		2.2	3	V
EN Rising Threshold	ENLDO	ENLDO Rising		1.4		V
EN Falling Threshold	ENLDO	ENLDO Falling		0.6		V



Output Voltage Accuracy			-3	1.5	3	%
Feedback Voltage	LDOOUT		0.588	0.6	0.612	V
Dropout($V_{IN}-V_{OUT}$)		$I_{OUT}=500mA$		0.3		V
PSRR		$V_{IN}-V_{OUT}=3.8V$ $I_{OUT}=500mA$ $F_{re} < 1kHz$		64		dB

WLED Driver Electrical Characteristics

($V_{IN} = 3.6V$, $T_A = 25^\circ C$ unless otherwise specified)

PARAMETER	SYMBOL	TEST CONDITIONS	MIN	TYP	MAX	UNIT
Input Voltage Range	V_{IN}		3.4		20	V
Input UVP Threshold		Input Voltage Falling		3		V
Operating Supply Current		Switching		0.15	0.3	mA
Quiescent Supply Current		Not Switching		50	100	μA
EN Rising Threshold	BSTEN	BSTEN Rising		1.4		V
EN Falling Threshold	BSTEN	BSTEN Falling		0.6		V
Output Voltage Accuracy			-3	1.5	3	%
Switching Frequency	F_{SW}			1.2		MHz
Maximum Duty Cycle	D_{MAX}		87	92		%
Switch Current Limit	I_{LIM}	Duty = 75%		2		A
Switch On Resistance		$I_{SW} = 100mA$		0.15		Ω
Switch Leakage Current		$V_{SW} = 10V$, $V_{IN} = 3V$			10	μA
Feedback Voltage				0.25		V
OVP threshold				30		V

RESET Monitor Electrical Characteristics

($V_{PULLUP} = 3.3V$, $T_A = 25^\circ C$ unless otherwise specified)

PARAMETER	SYMBOL	TEST CONDITIONS	MIN	TYP	MAX	UNIT
POR threshold	V_{HVOUT2}	V_{HVOUT2} rising	85	90	95	%
Delay time	T_{delay}	Delay before POR released		100		ms

GENERAL DESCRIPTION
Feature Description

DF3117 is a highly efficient and integrated Power Management IC for Smart Doorbell and Projector etc.. The device incorporates 4 high-efficiency synchronous buck regulators, 1 high-efficiency LED driver and 1 LDO that deliver 6 output voltages. The device also includes a reset monitor that provides a reset output signal for processor. Each of the buck regulators is specially designed for high-efficiency operation throughout the load range. The bucks are internally compensated to be stable with the recommended external inductors and capacitors as detailed in the application diagram. Synchronous rectification yields high efficiency for low voltage and high output currents. Additional features include soft-start, under-voltage protection, over-voltage protection, short-current protection, over-current protection and thermal overload protection. All BUCKs can operate in

automatic mode (PWM/PFM). At very light loads, BUCKs enter PFM mode and operate with reduced switching frequency and supply current to maintain high efficiency.

Soft start

Each of converters has an internal soft-start circuit that limits the in-rush current during startup. This allows the converters to gradually reach the steady-state operating point, thus reducing startup stresses and surges. During startup, the switch current limit is increased in steps. For BUCKs the soft start is implemented by increasing the switch current limit in steps that are gradually set higher. The startup time depends on the output capacitor size, load current and output voltage.

Current Limiting

A current limit feature protects the device and any external components during overload conditions. In PWM mode the current limiting is implemented by using an internal comparator that trips at current levels according to the buck capability. If the output is shorted to ground the device enters a timed current limit mode where the NFET is turned on for a longer duration until the inductor current falls below a low threshold, ensuring inductor current has more time to decay, thereby preventing runaway.

Startup Sequence

Once VDD1/VDD2/VDD3/VDD4/VPLDO reaches the UVP threshold and the ENABLE pin= High the BUCKX/LDO will start up.

Reset Monitor

The POR pin of DF3117 is an open-drain output between the POR pin and the GND pin. The power on reset output asserts low until the output voltage on the OUT2 pin exceeds the setting thresholds (91%) and the deglitch timer(100ms) has expired. Additionally, whenever the EN2 pin is low or open, POR immediately asserts low regardless of the output voltage.

When the POR is released (not asserted low) an external resistor connected to any external bias voltage pulls up this POR pin.

Under Voltage Protection (UVP)

VDD1/VDD2/VDD3/VDD4/VPLDO voltage is monitored for a supply under voltage condition, for which the operation of the device cannot be guaranteed. The part will automatically disable. To prevent unstable operation, the UVP has a hysteresis window. Each under voltage protection (UVP) will

disable it's outputs, Once the supply voltage is above the UVP hysteresis, the device will initiate a power-up sequence and then enter the active state.

Over Voltage Protection (OVP)

VDD1/VDD2/VDD3/VDD4 voltage is monitored for a supply over voltage condition, for which the operation of the device cannot be guaranteed. The purpose of OVP is to protect the part and all other components connected to the PMIC outputs from any damage and malfunction. Once VDD1/VDD2 rises over about 20V or VDD4 rises over about 38V, BUCKX will be disabled automatically. To prevent unstable operation, the OVP has a hysteresis window. An over voltage protection (OVP) will force the device into the reset state, Once the supply voltage goes below the OVP lower threshold, the device will initiate a power-up sequence and then enter the active state.

Thermal Shutdown(OTP)

The temperature of the silicon die is monitored for an over-temperature condition, for which the operation of the device cannot be guaranteed. The part will automatically be disabled if the temperature is too high. The thermal shutdown (OTP) will force the device into the reset state. In reset, all circuitry is disabled. To prevent unstable operation, the OTP has a hysteresis window of about 20°C. Once the temperature has decreased below the OTP hysteresis, the device will initiate a power-up sequence and then enter the active state. In the active state, the part will start up as if for the first time.

Detailed Design Procedure

Adjusting the Output Voltage

For BUCKX/ LDO, A resistor divider from the output node to the feedback pin sets the output voltage. recommends using 1% tolerance or better divider resistors. Start with fixed value for the R1 resistor and use Equation to calculate R2.

To improve efficiency at light loads, consider using larger-value resistors. If the values are too high, the regulator is more susceptible to noise, and voltage errors from the feedback input current are noticeable.

$$V_{OUT} = V_{FEEDBACK} \times \frac{R1 + R2}{R2}$$

Select R1 value then

$$R2 = R1 \times \frac{V_{FEEDBACK}}{V_{OUT} - V_{FEEDBACK}}$$

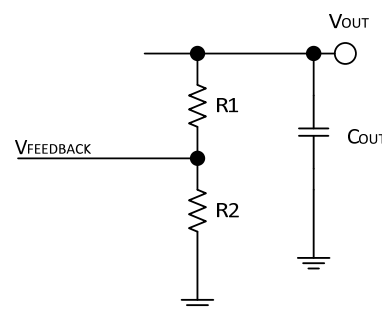

BUCK Power Supply Recommendations

VDD1/VDD2/BOOST input voltage supply range is between 3.4 V and 20V.

VDD4 input voltage supply range is between 6 V and 38V.

VDD3/VPLDO input voltage supply range is between 2.5 V and 6V

This input supply must be well regulated. If the input supply is located more than a few inches, additional bulk capacitance may be required in addition to the ceramic bypass capacitors.

VDDX/VPLDO must all be connected to input capacitors as close as possible.

BUCK Inductor Selection

For highest efficiency, select an inductor with a DC resistance less than 15mΩ. For most designs, derive the inductance value from the following equation.

$$L = \frac{V_{OUT} \times (V_{IN} - V_{OUT})}{V_{IN} \times \Delta I_L \times F_S}$$

Where ΔI_L is the inductor ripple current. Choose an inductor current approximately 30% of the maximum load current. The maximum inductor peak current is:

$$I_{L(MAX)} = I_{LOAD} + \frac{\Delta I_L}{2}$$

Under light-load conditions (below 100mA), use a larger inductor to improve efficiency.

BUCK Input Capacitor Selection

The input current to the step-down converter is discontinuous, and therefore requires a capacitor to both supply the AC current to the step-down converter and maintain the DC input voltage. For the best performance, use low ESR capacitors, such as ceramic capacitors with X5R or X7R dielectrics and small temperature coefficients. A 22μF capacitor is sufficient for most applications. The input capacitor requires an adequate ripple current rating because it absorbs the input switching. Estimate the RMS current in the input capacitor with:

$$I_{CIN} = I_{LOAD} \times \frac{\sqrt{V_{OUT} \times (V_{IN} - V_{OUT})}}{V_{IN}}$$

The worst-case condition occurs at $V_{IN} = 2V_{OUT}$, where:

$$I_{CIN} = \frac{I_{LOAD}}{2}$$

For simplification, choose an input capacitor with an RMS current rating greater than half the maximum load current. The input capacitor can be electrolytic, tantalum, or ceramic. Place a small, high-quality,

ceramic capacitor (0.1μF) as close to the IC as possible when using electrolytic or tantalum capacitors. When using ceramic capacitors, make sure that they have enough capacitance to provide sufficient charge to prevent excessive input voltage ripple. Estimate the input voltage ripple caused by the capacitance with:

$$\Delta V_{IN} = \frac{I_{LOAD}}{F_S \times C_{IN}} \times \frac{V_{OUT}}{V_{IN}} \times \left(1 - \frac{V_{OUT}}{V_{IN}}\right)$$

BUCK Output Capacitor Selection

The output capacitor (C_{OUT}) maintains the DC output voltage. Use ceramic, tantalum, or low-ESR electrolytic capacitors. Use low ESR capacitors to limit the output voltage ripple.

Estimate the output voltage ripple with:

$$\Delta V_{OUT} = \frac{V_{OUT}}{F_S \times L} \times \left(1 - \frac{V_{OUT}}{V_{IN}}\right) \times \left(R_{ESR} + \frac{1}{8 \times F_S \times C_{OUT}}\right)$$

Where L is the inductor value and RESR is the equivalent series resistance (ESR) of the output capacitor.

For ceramic capacitors, the capacitance dominates the impedance at the switching frequency and causes most of the output voltage ripple. For simplification, estimate the output voltage ripple with:

$$\Delta V_{OUT} = \frac{V_{OUT}}{8 \times F_S^2 \times L \times C_{OUT}} \times \left(1 - \frac{V_{OUT}}{V_{IN}}\right)$$

For tantalum or electrolytic capacitors, the ESR dominates the impedance at the switching frequency. For simplification, the output ripple can be approximated with:

$$\Delta V_{OUT} = \frac{V_{OUT}}{F_S \times L} \times \left(1 - \frac{V_{OUT}}{V_{IN}}\right) \times R_{ESR}$$

The characteristics of the output capacitor also affect the stability of the regulation system. The DF3117 can be optimized for a wide range of capacitance and ESR values.

BUCK Bootstrap Capacitor Selection

Connect a 22nF ceramic capacitor between the BST1/BST2 and SW1/SW2 pins for proper operation. Connect a 10nF/100nF ceramic capacitor between the BST4 and SW4 pins for proper operation recommends using a ceramic capacitor with X5R or better-grade dielectric. The capacitor should have a 6.3-V or higher voltage rating.

LDO Output Capacitor Selection

The LDO is designed to be stable with a minimum 4.7μF output capacitor. No series resistor is required

when using low ESR capacitors. For most applications, a 10μF ceramic capacitor is recommended. Larger values will improve transient response, and raise the power supply rejection ratio (PSRR) of the LDO. Refer to the Typical Performance Characteristics for the allowable range of output capacitor to ensure loop stability.

WLED Current Control

The DF3117 regulates the WLED current by setting the current sense resistor (R_{SENSE}) connecting to feedback and ground. As shown in typical application diagram, the WLED driver feedback voltage (BSTFB) is 0.25V. The WLED current (I_{WLED}) can be set by a resistor R_{SENSE} . In order to have an accurate WLED current, a precision resistor is preferred (1% is recommended).

$$I_{WLED} = \frac{0.25V}{R_{SENSE}}$$

WLED Driver Dimming Control

※Using a DC Voltage

Using a variable DC voltage to adjust the brightness is a popular method in some applications. According to the Superposition Theorem, as the DC voltage increases, the voltage contributed to BSTFB increases and the voltage drop on R1 decreases, i.e. the WLED current decreases. For example, if the VDC range is from 0V to 2.8V, the selection of resistors sets dimming control of LED current from 20mA to 0mA. The WLED current can be calculated by the following equation:

$$I_{WLED} = \frac{0.25V - \frac{R_1 \times (V_{DC} - 0.25V)}{R_2}}{R_{SENSE}}$$

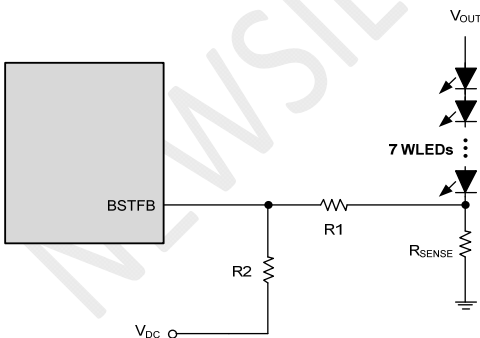

※Using a Filtered PWM signal

Another common application is using a filtered PWM signal as an adjustable DC voltage for WLED dimming control. A filtered PWM signal acts as the DC voltage to regulate the output current. Output ripple depends on the frequency of PWM signal. For smaller output voltage ripple (<100mV), the

recommended frequency of 2.8V PWM signal should be above 20kHz. To fix the frequency of PWM signal and change the duty cycle of PWM signal can get different output current.

The LED current can be calculated by the following equation:

$$I_{WLED} = \frac{0.25V - \frac{R_1 \times (V_{PWM} \times \text{Duty} - 0.25V)}{R_2 + R_3}}{R_{SENSE}}$$

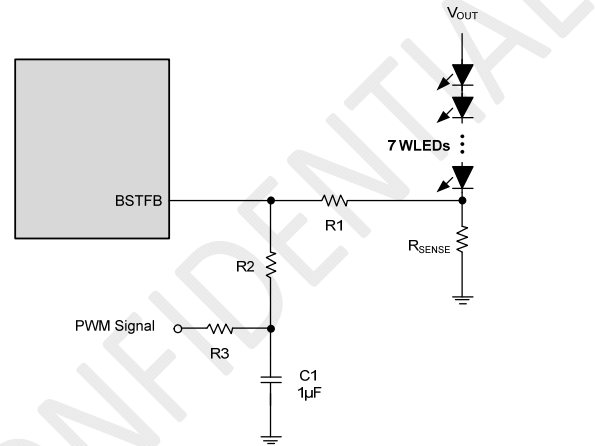

WLED Driver Inductor Selection

The recommended value of inductor for 3 to 7 WLEDs applications are 4.7 to 22μH. Small size and better efficiency are the major concerns for portable device, such as DF3117 used for MID. The inductor should have low core loss at 1.2MHz and low DCR for better efficiency. To avoid inductor saturation current rating should be considered.

WLED Driver Capacitor Selection

Input and output ceramic capacitors of 4.7μF are Recommended. For better voltage filtering, ceramic capacitors with low ESR are recommended. X5R and X7R types are suitable because of their wider voltage and temperature ranges.

WLED Driver Diode Selection

Schottky diode is a good choice because of its low forward voltage drop and fast reverse recovery. Using Schottky diode can get better efficiency. The high-speed rectification is also a good characteristic of Schottky diode for high switching frequency. Current rating of the diode must meet the root mean square of the peak current and output average current multiplication as following :

$$I_{D(RMS)} = \sqrt{I_{LOAD} \times I_{PEAK}}$$



The diodes reverse breakdown voltage should be larger than the output voltage. SS14 is recommended Schottky diode for rectifier.

Layout Guidelines

PC board layout is an important part of DC-DC converter design. Poor board layout can disrupt the performance of a DC-DC converter and surrounding circuitry by contributing to EMI, ground bounce, and resistive voltage loss in the traces. These can send erroneous signals to the DC-DC converter resulting in poor regulation or instability. Good layout can be implemented by following a few simple design rules.

1. Minimize area of switched current loops. In a buck regulator there are two loops where currents are switched rapidly. The first loop starts from the CIN input capacitor, to the regulator VIN terminal, to the regulator SW terminal, to the inductor then out to the output capacitor COUT and load. The second loop starts from the output capacitor ground, to the regulator GND terminals, to the inductor and then out to COUT and the load. To minimize both loop areas the input capacitor should be placed as close as possible to the VIN terminal. Grounding for both the input and output capacitors should consist of a small localized top side plane that connects to GND. The inductor should be placed as close as possible to the SW pin and output capacitor.

- 2. Minimize the copper area of the switch node. The SW terminals should be directly connected with a trace that runs on top side directly to the inductor. To minimize IR losses this trace should be as short as possible and with a sufficient width. However, a trace that is wider than 100 mils will increase the copper area and cause too much capacitive loading on the SW terminal. The inductors should be placed as close as possible to the SW terminals to further minimize the copper area of the switch node.
- 3. Have a single point ground for all device analog grounds. The ground connections for the feedback components should be connected together then routed to the GND pin of the device. This prevents any switched or load currents from flowing in the analog ground plane. If not properly handled, poor grounding can result in degraded load regulation or erratic switching behavior.
- 4. Minimize trace length to the FB terminal. The feedback trace should be routed away from the SW pin and inductor to avoid contaminating the feedback signal with switch noise.
- 5. Make input and output bus connections as wide as possible. This reduces any voltage drops on the input or output of the converter and can improve efficiency. If voltage accuracy at the load is important make sure feedback voltage sense is made at the load. Doing so will correct for voltage drops at the load and provide the best output accuracy.





PACKAGE

QFN28L_4X4

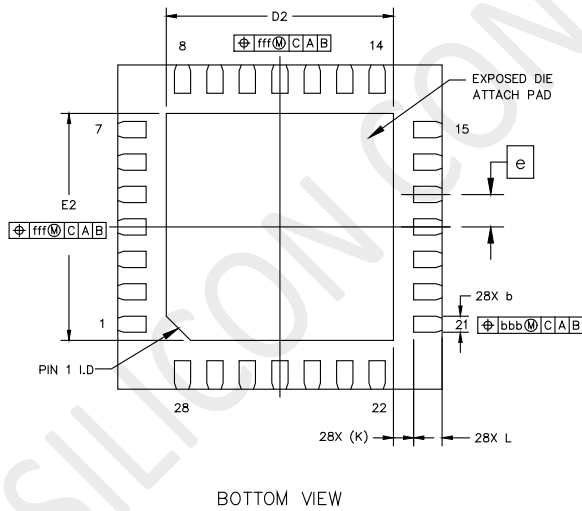
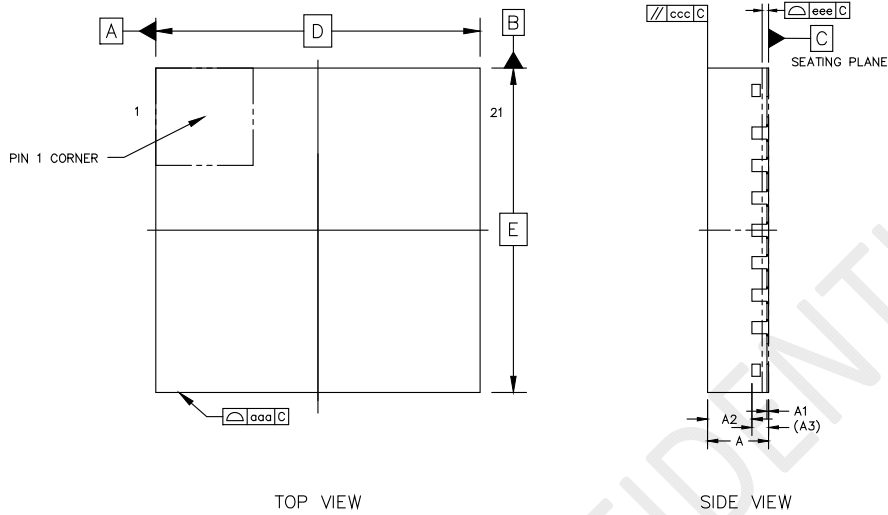

NOTES

- 1.REFER TO JEDEC MO-220;
- 2.COPLANARITY APPLIES TO LEADS, CORNER LEADS AND DIE ATTACH PAD;
- 3.BAN TO USE THE LEVEL 1 ENVIRONMENT-RELATED SUBSTANCES;

	SYMBOL	MIN	NOM	MAX
TOTAL THICKNESS	A	0.7	0.75	0.8
STAND OFF	A1	0	0.02	0.05
MOLD THICKNESS	A2	---	0.55	---
L/F THICKNESS	A3		0.203 REF	
LEAD WIDTH	b	0.15	0.20	0.25
BODY SIZE	X	D		
	Y	E		
LEAD PITCH	e	0.4 BSC		
EP SIZE	X	D2	2.7	2.8
	Y	E2	2.7	2.8
LEAD LENGTH	L	0.3	0.35	0.4
LEAD TIP TO EXPOSED PAD EDGE	K	0.25 REF		
PACKAGE EDGE TOLERANCE	aaa	0.1		
MOLD FLATNESS	ccc	0.1		
COPLANARITY	eee	0.08		
LEAD OFFSET	bbb	0.1		
EXPOSED PAD OFFSET	fff	0.1		

